

FLUORESCENT EMERGENCY BALLAST

3000 LUMENS (AC OUTPUT, TIME DELAY) INSTALLATION INSTRUCTIONS

When using this lighting device
safety precautions should be followed at all times

**PLEASE READ CAREFULLY AND FOLLOW ALL
INSTRUCTIONS FOR YOUR OWN SAFETY**

1. Prior to installation, battery connector must be open to prevent high voltage from being present on out put leads (red & yellow). It must be connected only after installation is complete and A.C. Power is supplied to the unit.
2. This unit can operate commonly used linear and compact fluorescent lamps. Please refer to the “lamps list” label on the ballast for specific lamp information.
3. Please ensure the electricity connections conform to the National Electrical Code and local regulations if applicable.
4. To avoid electric shock, please disconnect normal and emergency power supplies, and battery connector of the emergency ballast before servicing.
5. This device is designed for factory or field installation in either the ballast channel, or on top of the fixture, except air handling heated air outlets, sealed and gasketed fixtures, wet or hazardous location fixtures. Do not install this device near gas or electric heaters.
6. AC power source of 120 VAC or 277 VAC is required.
7. The battery is sealed, no-maintenance, and is not replaceable in the field. Please contact manufacturer for information on service. Do not attempt to service the battery please.
8. Do not use accessory equipment that is not recommended by manufacturer. Failure to do so may cause unsafe conditions. Servicing should only be performed by qualified service personnel.
9. Do not use the product for other than it's intended purpose.

CAUTION: Verify that all replacement lamp types marked on the installed luminaire are also identified as suitable for use with this inverter/charger pack.

PLEASE SAVE THESE INSTRUCTIONS

INSTALLATION INSTRUCTIONS

CAUTION: Before installing, make certain the A.C. Power is off and the **EMERGENCY BALLAST'S** unit connector is disconnected.

1. MOUNTING THE EMERGENCY BALLAST(BATTERY PACK)

Mount the **EMERGENCY BALLAST** on the back of the fixture as shown in diagram 1.

When battery packs are remote mounted, the remote distance can not exceed $\frac{1}{2}$ of the distance from ballast to lamp specified by the A.C. ballast manufacturer.

For example, if the A.C. ballast manufacturer recommends no more than 25' remote distance, then the battery pack's remote mounting distance should not exceed $12\frac{1}{2}'$. Under no circumstances should the battery pack exceed a distance of 50' from the lamp(s).

DIAGRAM 1

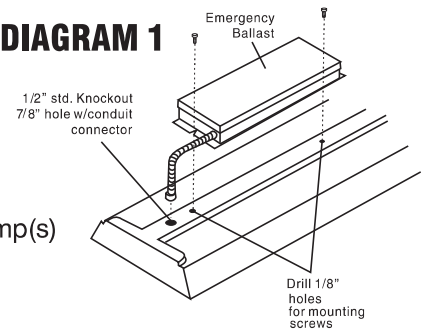

2. WIRING

Refer to the wiring diagrams on the back page for the appropriate wiring of lamp(s) and ballast. Install in accordance with the National Electrical Code and local regulations. For additional wiring diagrams consult Customer Service.

3. INSTALLING THE LED COMBO TEST SWITCH(LCTS)

Recessed Troffer Fixture - Select a convenient location with proper clearance in the ballast cover and drill or punch a $\frac{7}{8}$ " hole ($\frac{1}{2}$ " knockout). Insert the $\frac{7}{8}$ " bushing into the hole. Push the plastic tube through the bushing. Route the leads of the **LCTS** through the plastic tube. Connect the wires from the unit to the **LCTS** (VIOLET to VIOLET, BROWN to BROWN). Push the entire assembly back into the tube until the lens collar rests against the plastic tube. The plastic tube should be adjusted so that the **LCTS** is within $\frac{1}{4}$ " of the fixture lens. The **LCTS** must be visible after installation. Refer to *Illustration 1*.

Strip Fixture - Select a convenient location on the fixture so the **LCTS** can be seen after installation. Allow for proper clearance inside the fixture and drill or punch a $\frac{1}{2}$ " hole. Remove the nut from the **LCTS**. Push the **LCTS** housing into the $\frac{1}{2}$ " hole and secure with the nut. Connect the wires from the **LCTS** (VIOLET to VIOLET, BROWN to BROWN). Refer to *Illustration 2*.

Illustration 1

Illustration 2

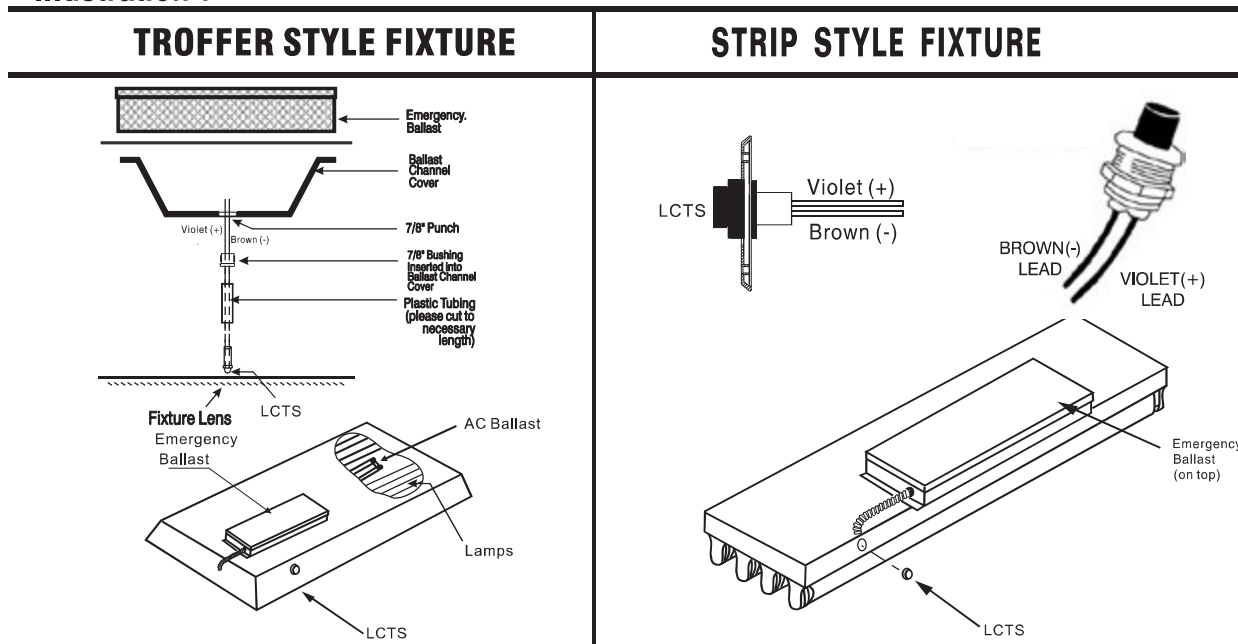

4. WIRING THE A.C. INPUT

- The **EMERGENCY BALLAST** and A.C. ballast **must** be on the same branch circuit
- The **EMERGENCY BALLAST** requires an **unswitched** A.C. power source of either 120 or 277 volts. Select the proper voltage lead and cap the unused lead.
- When the **EMERGENCY BALLAST** is used with a switched fixture, A.C. Input to the **EMERGENCY BALLAST** must be connected ahead of the fixture switch. Refer to *Illustration 3* for switched and unswitched fixture wiring diagrams.

5. BALLAST WIRING BLOCK DIAGRAM

Illustration 3

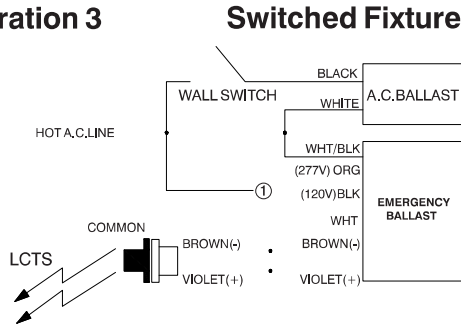

① Select proper voltage lead. Cap unused lead.

Unswitched Fixture

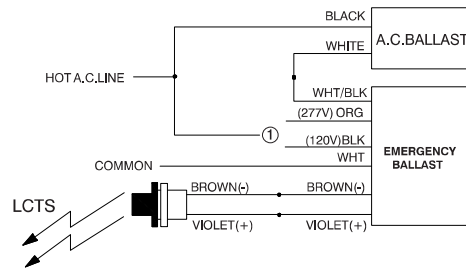

① Select proper voltage lead. Cap unused lead.

6. LABELS

Attach the appropriate labels adjacent to the **LCTS**. Annotate Re-lamping label for lamp type and wattage. The 'Caution' and the 'Re-lamping' labels must be on the fixture in a readily visible location to anyone attempting to service the fixture.

7. COMPLETING INSTALLATION

When the installation is complete, switch the A.C. power ON and join the **EMERGENCY BALLAST**'S unit connector.

OPERATION

Normal Mode - A.C. power is present. The A.C. ballast operates the fluorescent lamp(s) as intended. The **LCTS** will be lit providing a visual indication that the **EMERGENCY BALLAST** is in the standby charging mode.

Emergency Mode - A.C. power fails. The **EMERGENCY BALLAST** senses the A.C. power failure and automatically switches to the *Emergency Mode*. One or two lamps illuminate at reduced output, for a minimum of 90 minutes. When A.C. Power is restored, the **EMERGENCY BALLAST** switches the system back to the *Normal Mode* and resumes battery charging.

TESTING & MAINTENANCE

Pressing the red lens on the **LCTS** turns off the light on it, interrupts power to the designated A.C. ballast and forces the unit into emergency mode. The emergency lamp (s) is (are) now lit by the **EMERGENCY BALLAST**. On releasing the lens, fixture returns to normal mode after a momentary delay. To simulate a "BLACK OUT" use the circuit breaker to turn off the AC power.

Initial Testing - Allow the unit to charge for approximately 1 hour, then press the **LCTS** to conduct a short discharge test. Allow a 24 hour charge before conducting a 1½ hour test.

This **EMERGENCY BALLAST** is a maintenance free unit, however, periodic inspection and testing is required. NFPA 101, Life Safety Code, outlines the following schedule:

Monthly - Insure that the **LCTS** is illuminated. Conduct a 30 second discharge test by depressing the **LCTS**. One lamp should operate at reduced output.

Annually - Insure that the **LCTS** is illuminated. Conduct a full 1½ hour discharge test. The unit should operate as intended for the duration of the test.

"Written records of testing shall be kept by the owner for inspection by the authority having jurisdiction."

SERVICING SHOULD BE PERFORMED BY QUALIFIED PERSONNEL

WIRING DIAGRAMS FOR 1-LAMP EMERGENCY OPERATION

EMERGENCY BALLAST AND AC BALLAST MUST BE FED FROM THE SAME BRANCH CIRCUIT

TYPICAL SCHEMATICS ONLY. MAY BE USED WITH OTHER BALLASTS. CONSULT THE FACTORY FOR OTHER WIRING DIAGRAMS.

E. ONE (1) LAMP INSTANT START BALLAST

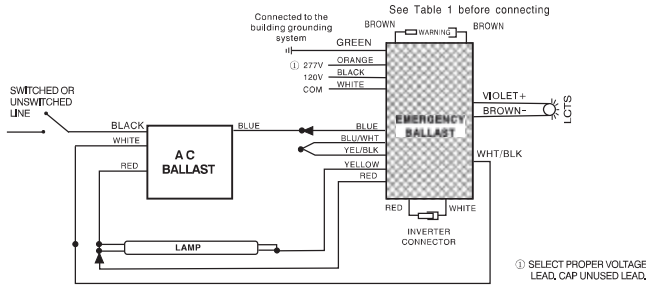

F. TWO (2) LAMP INSTANT START BALLAST

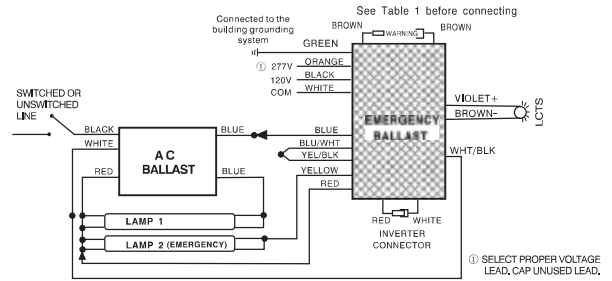

G. THREE (3) LAMP INSTANT START BALLAST

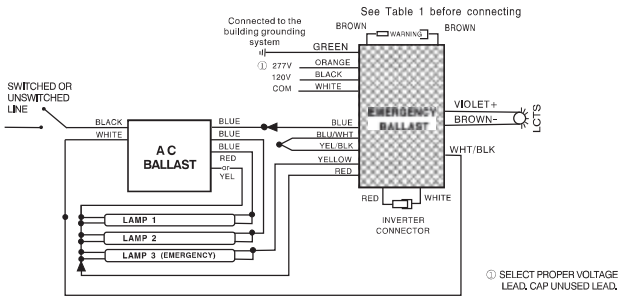

H. FOUR (4) LAMP INSTANT START BALLAST

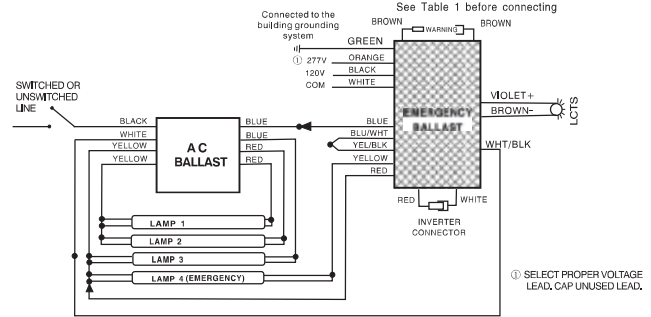

I. ONE (1) 4-PIN COMPACT LAMP RAPID START BALLAST

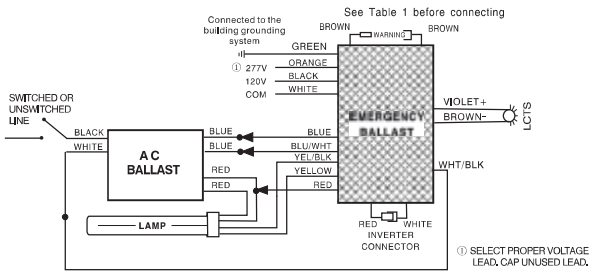

J. TWO (2) 4-PIN COMPACT LAMP RAPID START BALLAST

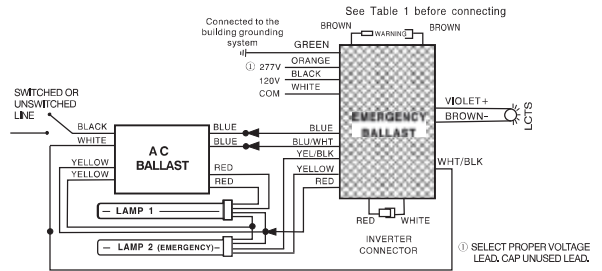

K. ONE (1) LAMP CIRCLINE RAPID START BALLAST

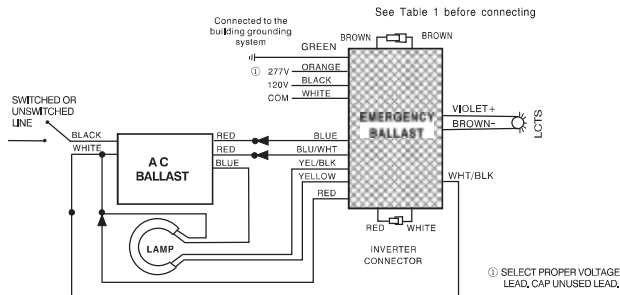

L. TWO (2) LAMP CIRCLINE RAPID START BALLAST

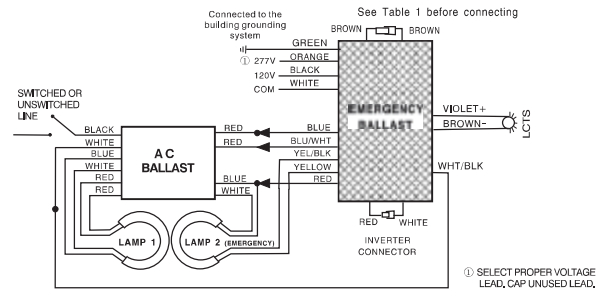

NOTE : USE PROPER TAP TO CAP UNUSED LEAD

WIRING DIAGRAMS FOR 2-LAMP EMERGENCY OPERATION

EMERGENCY BALLAST AND AC BALLAST MUST BE FED FROM THE SAME BRANCH CIRCUIT

TYPICAL SCHEMATICS ONLY. MAY BE USED WITH OTHER BALLASTS. CONSULT THE FACTORY FOR OTHER WIRING DIAGRAMS.

Two-lamp emergency operation is not possible with all ballasts.
Consult the factory for any ballast other than those shown below.

M. TWO (2) LAMP RAPID START BALLAST

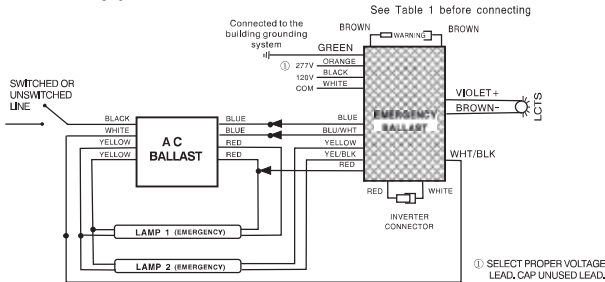

N. TWO (2) LAMP INSTANT START BALLAST

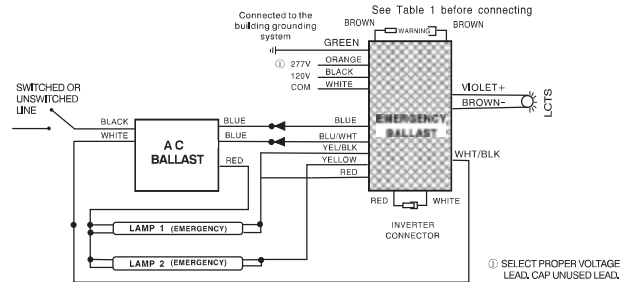

O. THREE (3) LAMP RAPID START BALLAST

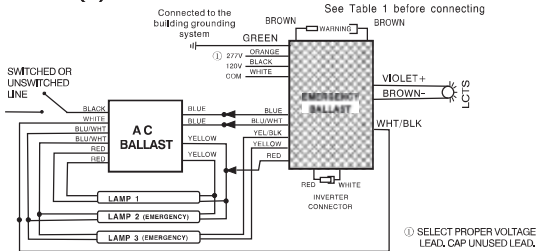

P. THREE (3) LAMP INSTANT START BALLAST

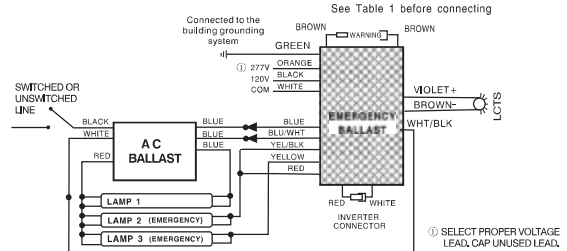

Q. FOUR (4) LAMP RAPID START BALLAST

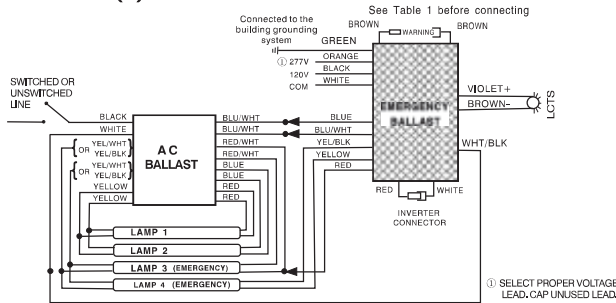

R. FOUR (4) LAMP INSTANT START BALLAST

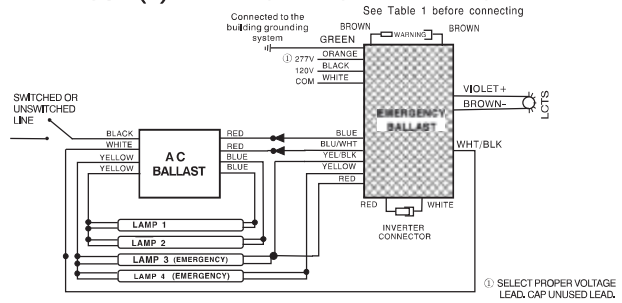

WIRING DIAGRAMS for EMERGENCY-ONLY fixtures

S. ONE (1) LAMP WITHOUT AC BALLAST

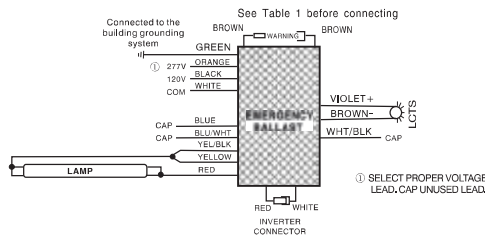

T. TWO (2) LAMPS WITHOUT AC BALLAST

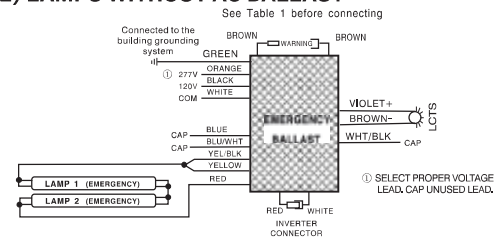

U. ONE (1) 4-PIN COMPACT LAMP WITHOUT AC BALLAST

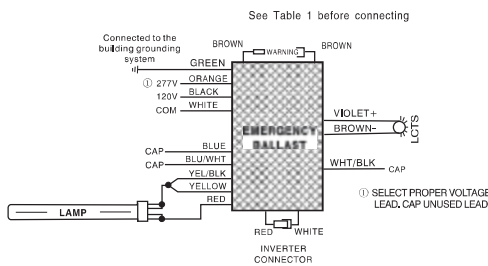

V. TWO (2) 4-PIN COMPACT LAMPS WITHOUT AC BALLAST

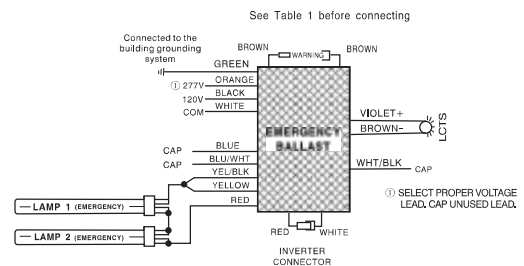

NOTE : USE PROPER TAP TO CAP UNUSED LEAD

WIRING DIAGRAMS FOR 1-LAMP EMERGENCY OPERATION

EMERGENCY BALLAST AND AC BALLAST MUST BE FED FROM THE SAME BRANCH CIRCUIT

TYPICAL SCHEMATICS ONLY. MAY BE USED WITH OTHER BALLASTS. CONSULT THE FACTORY FOR OTHER WIRING DIAGRAMS.

A. ONE (1) LAMP RAPID START BALLAST

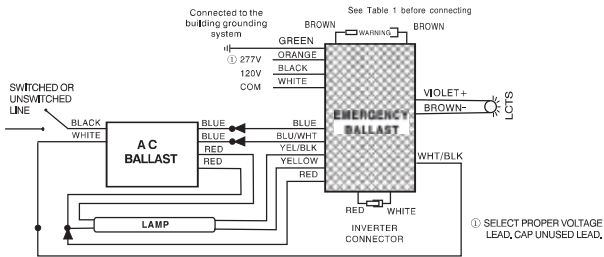

B. TWO (2) LAMP RAPID START BALLAST

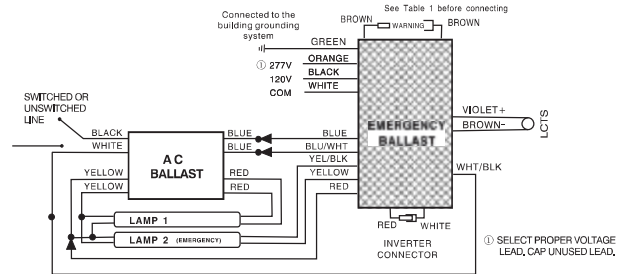

C. THREE (3) LAMP RAPID START BALLAST

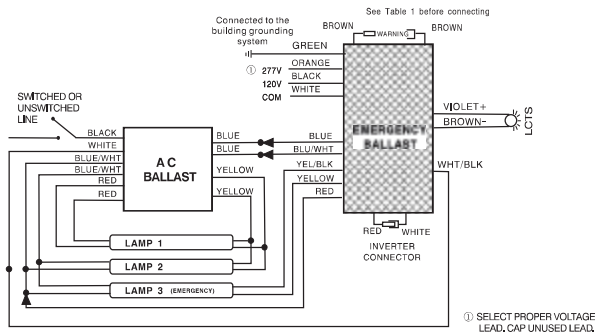

D. FOUR (4) LAMP RAPID START BALLAST

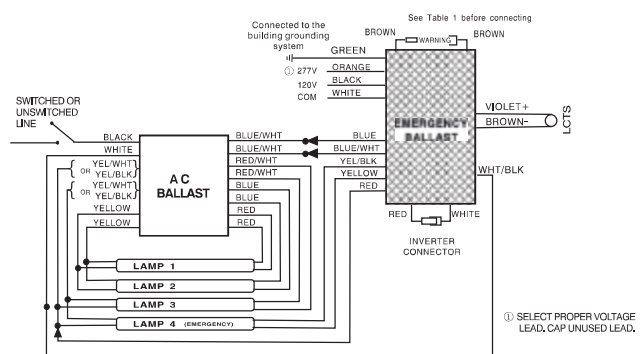

NOTE : USE PROPER TAP TO CAP UNUSED LEAD

WIRING DIAGRAMS:

The following diagrams are typical schematics only. May be used with other ballasts. Consult the factory for other wiring diagrams. Emergency Ballast and AC Ballast must be fed from the SAME BRANCH CIRCUIT.

TABLE 1 (FOR BROWN CONNECTOR)

LAMP DIAMETER	BASE TYPE	WATTAGE (LENGTH)	NO.OF LAMPS (EMERGENCY MODE)	BROWN CONNECTOR
T5 (for Emergency-only operation)	SINGLE OR BIPIN	8,14,21W (1'-2'-3')	1/2	CLOSE
T5 (for Emergency-only operation)	SINGLE OR BIPIN	28W (4')	1	CLOSE
T5 (for Emergency-only operation)	SINGLE OR BIPIN	28W (4')	2	OPEN
T5 HO (for Emergency-only operation)	SINGLE OR BIPIN	39W (3')	1	CLOSE
T5 HO (for Emergency-only operation)	SINGLE OR BIPIN	39W (3')	2	OPEN
T5 HO (for Emergency-only operation)	SINGLE OR BIPIN	54W (4')	1	CLOSE
T5 HO (for Emergency-only operation)	SINGLE OR BIPIN	54W (4')	2	OPEN
T8	SINGLE OR BIPIN	17,25,32W (2'-3'-4')	1/2	CLOSE
T8	SINGLE OR BIPIN	40W (4'/5')	1	CLOSE
T8	SINGLE OR BIPIN	40W (4'/5')	2	OPEN
T12	SINGLE OR BIPIN	20,34,40W (2'-4'-4')	1/2	CLOSE
T12	SINGLE OR BIPIN	110W (8')	1	CLOSE
T12	SINGLE OR BIPIN	215W (8')	1	OPEN
COMPACT	G24q-1(4pin) G24q-2(4pin) G24q-3(4pin)	13,18,26W	1/2	CLOSE
LONG COMPACT	2G11(4pin)	18,24,36W	1/2	CLOSE
LONG COMPACT	2G11(4pin)	40W	1	CLOSE
LONG COMPACT	2G11(4pin)	40W	2	OPEN
LONG COMPACT	2G11(4pin)	50W	1	CLOSE
LONG COMPACT	2G11(4pin)	50W	2	OPEN
CIRCULAR T9	4-pin	20,32,40W	1/2	CLOSE
U-bend T8	Bi-pin	32W	1/2	CLOSE
U-bend T12	Bi-pin	34W	1/2	CLOSE