

PROJECT:	TYPE:
LOCATION:	CAT:



Black

Description

Use Commercial Grade Light String for decorative, event oriented, or festive lighting applications.

Features

- cETLus Listed 14AWG SJTW 3-wire light string in 48ft interconnectable kits with 120V plug and socket (interconnectable male/female ends)
- Formulated PVC sockets form a tight seal around bulbs to preclude the entrance of water and moisture
- Suspended socket has T-mold with mounting hole at top
- Use with E26 base Long Life Incandescent Lamps or Pro Decorative Lamps (sold separately)

Mounting

For spans up to 20 feet, use eye bolts and plastic ties to anchor ends. For spans longer than 20 feet, use catenary cable (sold separately) with plastic ties at each socket.

Applications

Patios, overhangs, outdoor living areas, tents for weddings or festivals, event lighting



Technical Information

Series	ETLS-MS-24-48-BK
Length	48ft
Socket Type	Suspended E26 Base
Socket Spacing	24"
Total Sockets	24
Wire Color	Black
Wire Type	14AWG SJTW 3-wire with 120V plug and socket (interconnectable male/female ends)
Voltage	120V AC, 60Hz
Max Watts Per Socket	40 watts max per socket
Max Run	Interconnectable up to 1440 watts
Cuttability	N/A
Rating	cETLus Listed; Outdoor, year-round use; IP64
Rated Life	Varies by lamp used

ETLS-MS Socket Dimensions

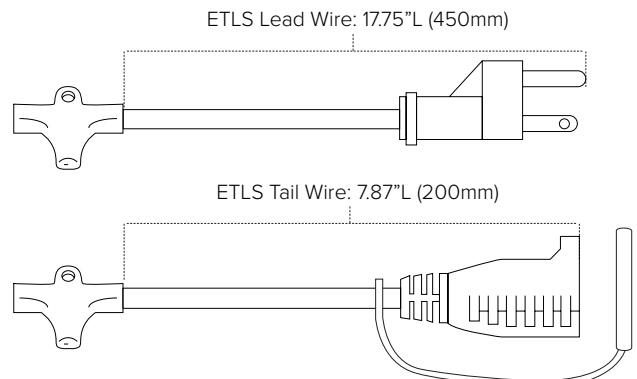
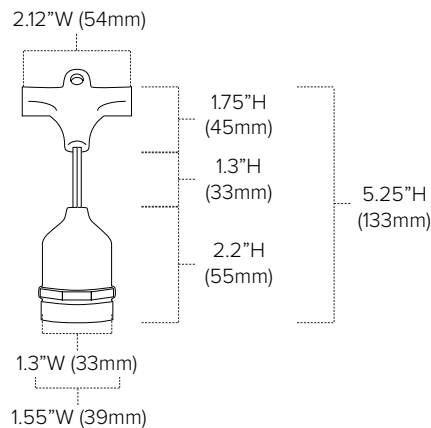





Ordering Information

120V ETLS Series 48ft Interconnectable Sets

PRODUCT	MODEL	Socket Spacing	Length	Length
ETLS	MS	24	48	BK
	MS = E26 Suspended Base	24 = 24 inches	48 = 48 feet	BK = Black

120V ETLS Series 48ft 'Cord and Plug' Sets Include:
(1) 48ft length of ETLS series commercial grade light string with 120V plug and socket (interconnectable male/female ends)

Accessories

Image	Item	Description
	Compatible Lamps	Pro Decorative Series: PS14-E26, PA15-E26, PG50-E26, PG45-E26, and PG40-E26 Standard LED Series: S14-LED Long Life Incandescent B-Series: B7.5S11 and B11S14
	LS-CABLE-60	60ft Catenary Cable Kit Includes: (1) 60ft length of 1/8" diameter catenary/guide cable for light string installation, (2) Heavy duty cable locks, and (1) Cable release key
	LS-CABLE-110	110ft Catenary Cable Kit Includes: (1) 110ft length of 1/8" diameter catenary/guide cable for light string installation, (2) Heavy duty cable locks, and (1) Cable release key
	LS-CABLE-500	500ft Catenary Cable Bulk Reel Includes: (1) 500ft length of 1/8" diameter catenary/guide cable for light string installation
	LS-LOCK-4	(4) Heavy duty cable locks for 1/8" catenary cable; Support loads up to 330lbs; Includes cable release key
	LS-TT	Tensioning Tool; use to eliminate sag from catenary cable. Never tighten cable before load is attached; Never over-tighten cable

Additional Information

SUSPENDING LIGHT STRINGS:

Light sockets must be suspended so that bulbs are facing down only. **DO NOT MOUNT THE LIGHT STRINGS WITH SOCKETS FACING UPWARD!**

- Light string must be securely attached to a support structure at each end of each span. The maximum unsupported span distance for 48' Cord & Plug Light String is 20 feet (10 sockets).
- Secure light string to supporting hardware (eyebolts, brackets, etc., not provided) using cable ties (not included). See Figure 1.
- Cover the unused female receptacle at the last light string with attached end cap and electrical tape to preclude the entrance of water.
- For spans exceeding 20 feet, use properly rated cable support system and cable ties (neither are provided with the light string) and follow local codes for suspended cables and loads. See www.americanlighting.com for steel cable support systems, if needed.

