



LED LUMINAIRES

LED Vaportight Series



High Performance
LED Technology



IP65 Rated



50,000 Hour Life

Long-lasting, low maintenance, energy efficient replacements for Incandescent and HID luminaires



Available in Ceiling and Wall Mount Designs

Up to 75% Energy Savings vs. HID

5-Year Limited Warranty

Applications:

Ideal for use where Dust, Dirt, Humidity and Moisture are Present.

Markets:

Commercial
Industrial



where there's light, there's halco®

Contact Your Customer Care Specialist For Pricing, Orders And Technical Support.

800.677.3334 www.halcolighting.com

LED Vaportight Series

Product #: _____ Type: _____

Project: _____ Date: _____

Comments: _____ Initials: _____

Specifications

- Operating temperature range is -40°F (-40°C) to 113°F (45°C)
- Die-cast aluminum housing with screw-on guard
- Repaintable textured gray powdercoat finish
- Silicone gaskets protect against rust, corrosion, dirt and insects
- Clear glass globe
- Removable 1/2" threaded plugs with O-rings for conduit access and photocell provision
- Weatherproof box with removable threaded 3/4" plugs and O-rings for 3/4" conduit access
- Electrical snap-in connectors to simplify wiring and installation
- Voltage sensing 100-277V dimmable driver
- CSA Listed for wet locations

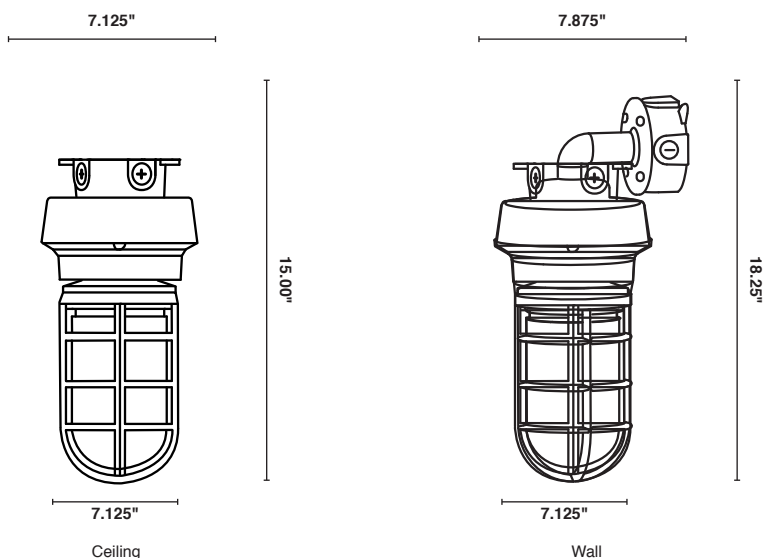

Ordering Information



Watt	Product #	Product Code	Volts	Color Temp.	CRI	Lumens	Useful Life*	Pkg. Qty.	Dimmable	Equivalent Wattage
13	99904	VT1/CL13GRY50/CM/LED	100-277V	5000	80+	911	50,000	1	0-10V	70
13	99905	VT1/CL13GRY50/WM/LED	100-277V	5000	80+	911	50,000	1	0-10V	70

IP65 Rated luminaires are rated for use outdoors where exposed directly to water from rain or irrigation.

* Useful Life is defined as the point in time at which the lamp will maintain at least 70% of its initial lumens. The lamp will continue to burn past this point, but at decreased light levels.

Warranty – Commercial / Industrial: This product is warranted for 5 years from the date of purchase, based on 10 hours of use per day.