

# LS-301

## Dimming Photosensor

# Installation Instructions



### SPECIFICATIONS

Current Consumption .....	30mA@24VDC
Power Supply .....	24VDC from WattStopper Power Pack
Ballasts .....	0-10VDC standard dimming
Max Ballasts Controlled.....	50 Ballasts
Min Signal to ballast .....	0.2VDC
Max Signal to ballast.....	10VDC

**WattStopper®**

Santa Clara, CA 95050

## UNIT DESCRIPTION

The LightSaver® LS-301 is a low voltage, indoor dimming photosensor. It provides a continuous dimming signal to 0-10VDC dimming ballasts. The LS-301 is a "closed loop" system, it considers both daylight and artificial light when adjusting light levels. It uses a sliding setpoint control algorithm to maintain the desired illuminance levels for separate night and day target setpoints. The LS-301 slowly raises or lowers the electric lights to avoid sudden changes that can annoy occupants.

After the LS-301 is installed, all adjustments are made using the LSR-301-S remote control setup tool. The optional remote control (LSR-301-P) allows the occupant to adjust light levels.

## COVERAGE PATTERN

The LS-301 lens is rectangular. An arrow on the lens housing indicates the direction of the photosensor's broadest view. It is intended to be mounted on the ceiling (or it may be factory mounted within a lighting fixture).

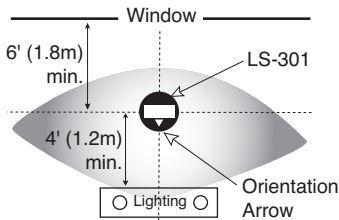

Fig.1: Coverage pattern and typical placement

## Placement Guidelines

Placement of the LS-301 is critical to its overall performance. The photosensor must be aimed to view the area illuminated by the lights that it controls.

- Position the photosensor in a location with a light level that is representative of the entire controlled area or the least illuminated work space in the controlled area.
- Avoid installing multiple sensors in adjoining areas where the light from one controlled fixture spills over into the view of the next photosensor.
- When the primary source of daylight is a window, mount the photosensor no closer than 6 feet (1.8m) to the window and no farther away than 15 feet (4.5 m). The arrow on the photosensor should point away from the window.
- In applications with direct/indirect pendant fixtures, do not mount the photosensor on the ceiling within 4 feet (1.2m) of the pendant fixtures.
- Avoid mounting the photosensor above extremely reflective surfaces such as highly polished floors or tables, if possible.

## Alternate placement

When direct/indirect pendant light fixtures are installed less than 10 feet (3m) from the window it may be necessary to mount the LS-301 so that its view is away from the nearest fixture, as shown in Figure 2.

Follow the Placement Guidelines previously described..

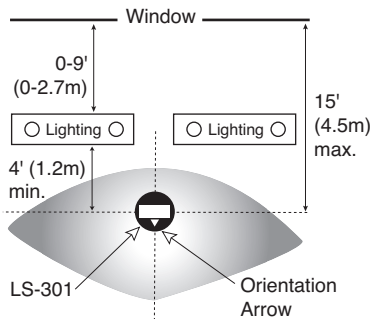

**Fig.2: Placement in applications where lighting fixtures are within 10 feet (3m) of daylight source**

## BURN-IN

### WARNING

### "BURN-IN" PERIOD REQUIRED

Follow the lamp manufacturer's recommendation on lamp burn-in for new lamps prior to dimming the lamps with the LS-301. Typical recommendations are for 100 hours of operation at 100% light output. If the lamp manufacturer's guidelines are not followed, premature lamp failure may occur.

When it is first installed and connected to the fixtures, the LS-301 will drive the lamps at full output until the Night adjustment has been completed using the LSR-301-S remote control.

The amber LED under the photosensor's lens flashes continuously until the Night and Day adjustments have been properly completed.

**Call 800.879.8585 for Technical Support**

## MOUNTING INSTRUCTIONS



**CAUTION**



**TO PREVENT ELECTRIC SHOCK, DISCONNECT POWER TO THE DIMMING BALLAST BEFORE CONNECTING THE PHOTOSENSOR.**

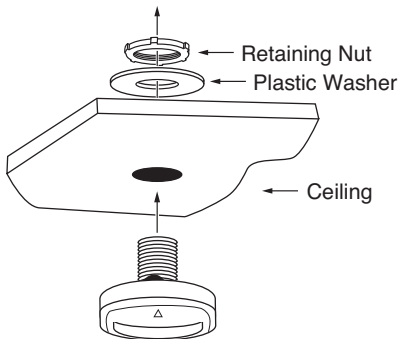

### **Note:**

The LS-301 can be mounted to a junction box in areas where low voltage connections are required to be enclosed.

1. Drill or cut a 13/16" (20mm) hole in the ceiling tile where the photosensor is to be mounted.
2. Guide the wires and threaded tube of the photosensor through the hole.
3. Slide the plastic washer around the tube.
4. Make sure the photosensor's view is set according to the proper placement guidelines described earlier in these instructions.
5. Tighten the retaining nut to prevent the photosensor from rotating.

**Visit our website for FAQs: [www.wattstopper.com](http://www.wattstopper.com)**



**CAUTION**



**TURN POWER OFF AT THE CIRCUIT BREAKER  
BEFORE WORKING WITH OR NEAR HIGH VOLTAGE.**

## WIRING

### Standard Installation

- Grey wire from dimming ballasts to Grey wire from photosensor.
- Violet wire from dimming ballasts to Violet wire from photosensor.
- Red wire from power pack to Red wire from photosensor.
- Black wire from power pack to Black wire from photosensor.

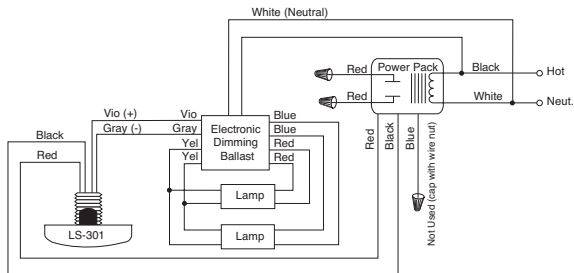

Typical Wiring

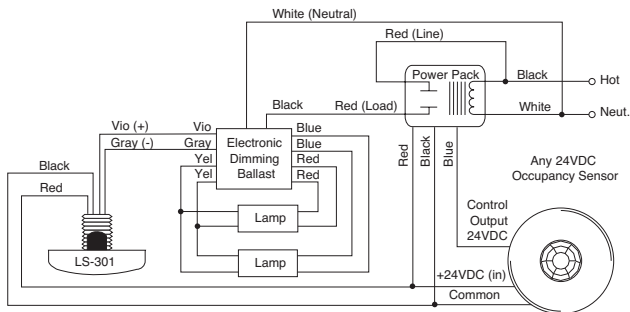

Wiring with Occupancy Sensor

**Call 800.879.8585 for Technical Support**

## PHOTOSENSOR ADJUSTMENT

The photosensor must be adjusted under two conditions, **Night** and **Day**. Either adjustment may be completed first. The photosensor begins automatic dimming control after both adjustments have been completed.

Initial adjustments to the LS-301 are done using the LSR-301-S remote control. The LSR-301-S has 5 buttons. The LED on the remote control should light every time you press a button. The red LED on the LS-301 photosensor also flickers for the duration of the press.

▲ (up arrow): Press to raise the intensity of the lights.

▼ (down arrow): Press to lower the intensity of the lights.

**Night:** Press to begin and end the Night adjustment.

**Auto:** Press to begin automatically dimming the lights.

**Day:** Press to begin and end the Day adjustment process.

### Conditions for Setup

Adjust the LS-301 after the controlled zone is furnished and ready for move-in. Placement of furniture affects the way light reflects from various surfaces.

- Furniture, floor and wall coverings must be clean.
- Window coverings must be clean and operable.
- Remove unnecessary objects such as tools and installation materials from the view of the photosensor.
- Do not block primary sources of electric light or daylight from reaching the photosensor's view.

**Blinds:** If window blinds are used, they must be lowered to cover the window. Adjust the blades so that they are horizontal (parallel to the floor) unless there is direct beam sunlight entering the space. Adjust the blinds to block the direct beam sunlight from entering the controlled zone.

**Lights from other areas:** If non-dimmed lights in adjoining areas contribute to the light viewed by the photosensor, these lights must be on during both Day and Night adjustments.

### Target Illuminance Levels

Before beginning any adjustment, determine the illuminance required for the space under both Night and Day conditions. The Night illuminance level must always drive the ballasts more than the Day level. If it does not, the amber LED on the LS-301 flashes to indicate an invalid setpoint. The amber LED will flash until both levels are properly adjusted.

Use a light meter to measure light levels. Choose a reference location that is most likely to have the lowest light level when daylight and is located farthest from the window or skylight. Use this reference location for all illumination readings.

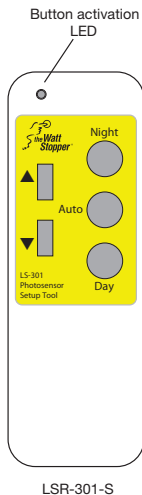

## Night Adjustment

Make this adjustment when there is less than 2 footcandles of daylight illumination at the reference location. Switch off the controlled lights and measure the level to make sure it is less than 2 footcandles.

1. Press the **Night** button once. The red LED on the LS-301 flickers.
2. Press ▲ or ▼ to adjust light level. Use a light meter to measure the level.
3. Once the target level has been reached, press and HOLD the **Night** button for 3 seconds. The LS-301 will acknowledge the setting of the Night target setpoint by lighting the red LED twice for 3 seconds each time.

## Day Adjustment

Make this adjustment when there is enough daylight to provide 40% to 90% of the target light level. For example, if the target is 40 footcandles, make this adjustment when the daylight contribution is between 16 and 36 footcandles.

To determine the contribution of daylight, switch off the electric lights, and measure the light level. If there is too much daylight reschedule the adjustment for a time when less daylight is present, such as early morning.

1. Press the **Day** button once. The red LED on the LS-301 flickers.
2. Press ▲ or ▼ to adjust light level. Use a light meter to measure the level.
3. Once the target level has been reached, press and HOLD the **Day** button for 3 seconds. The LS-301 will acknowledge the setting of the Day target setpoint by lighting the red LED twice for 3 seconds each time.

## Begin Automatic Dimming

Ten minutes after the last keypress of any adjustment (step 3):

- If only Night is done, the signal to the ballast remains at the level to which it was adjusted and the amber LED continues to flash.
- If only Day is done, the signal to the ballast goes to full output (10VDC) and the amber LED continues to flash.
- If Night **and** Day are both done, the LS-301 begins automatic dimming.

**NOTE:** To immediately begin automatic dimming after the Night and Day adjustments are BOTH completed, press the **Auto** button.

## USER CONTROL

The user can raise the target light level by up to 25% or reduce it to the lamp/ballast minimum with the LSR-301-P Personal Lighting Remote Control.

Pressing the ▲ (up arrow) or ▼ (down arrow) raises or lowers the target light level. The LS-301 will continue automatic dimming to maintain the new target light level until another button is pressed. Pressing **Auto** cancels the user adjusted target light level. The LS-301 returns to automatic dimming using the levels set with the LSR-301-S.

## TROUBLESHOOTING

### Excessive dimming

Mounting the photosensor near windows where large amounts of sunlight could strike or reflect onto the photosensor may cause the photosensor to over dim the lights. Move the photosensor further from the window or to a less exposed position. Refer to "Placement Guldelines" for possible problems.

### Unexpected dimming changes

Check the position of the photosensor. If it has rotated out of the correct viewing position, re-orient the photosensor and tighten the retaining nut inside the ceiling.

### Not automatically dimming

The photosensor will not provide automatic dimming until both Night and Day adjustments have been completed. Repeat the adjustment procedure.

### Photosensor not responding to remote

Carefully aim the remote at the photosensor. Press an arrow key and observe the LED on the remote. If it does not flicker while you press the key, check the remote batteries. If it lights, press an arrow again and observe the LED on the photosensor. If it does not flicker, check power and wiring to the photosensor.

### Flashing Amber LED on photosensor

Daytime ballast signal is higher than Night setting, or Night and Day adjustment not complete. Repeat the Night and Day target illuminance level adjustments.

## ORDERING INFORMATION

Catalog #	Description
LS-301	Dimming Photosensor, 24VDC
LSR-301-S	Setup Remote Control
LSR-301-P	Occupant Remote Control
BZ-50 or BZ-150	Power Pack: 120/277VAC, 50/60Hz, 225mA

## WARRANTY INFORMATION

WattStopper warrants its products to be free of defects in materials and workmanship for a period of five (5) years. There are no obligations or liabilities on the part of WattStopper for consequential damages arising out of or in connection with the use or performance of this product or other indirect damages with respect to loss of property, revenue, or profit, or cost of removal, installation or reinstallation.

# WattStopper®

2800 De La Cruz Boulevard, Santa Clara, CA 95050  
Technical Support: 800.879.8585 • [www.wattstopper.com](http://www.wattstopper.com)

03635r3 4/2013

Please  
Recycle

