



LED LUMINAIRE

ProLED[®] Linear LED High Bay Series II



RoHS Compliant



Dimmable



UL Listed



5 Year Warranty



DLC PREMIUM

The Linear LED High Bay Series II solution is great for commercial and industrial applications



Small Foot Print, High Performance

DLC Premium Qualified

110,000 Hour Rated Life

Dimmable (0-10V)

Emergency Options

Backed by a 5-Year Warranty

Applications:

Warehouses
Distribution Centers
Industrial facilities
Gymnasiums
Retail
Grocery Stores

Markets:

Industrial
Commercial

Halco[®]
LIGHTING TECHNOLOGIES

Contact Your Customer Care Specialist
For Pricing, Orders And Technical Support.

800.677.3334 www.halcolighting.com

ProLED[®]

Linear LED High Bay Series II

Product #: _____ Type: _____

Project: _____ Date: _____

Comments: _____ Initials: _____

Specifications

- >130 lumens per watt
- 0-10V dimming
- 5000K color temperature
- Emergency options
- 110,000 hour life
- V-Mount hooks included
- UL listed for damp locations

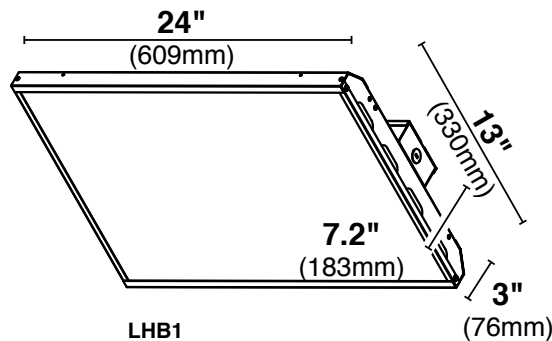

LHB1

Ambient Temp.	Rated Life
77°F(25°C)	110,000 Hours
86°F(30°C)	100,000 Hours
95°F(35°C)	90,000 Hours
104°F(40°C)	80,000 Hours
113°F(45°C)	70,000 Hours
122°F(50°C)	60,000 Hours
131°F(55°C)	50,000 Hours

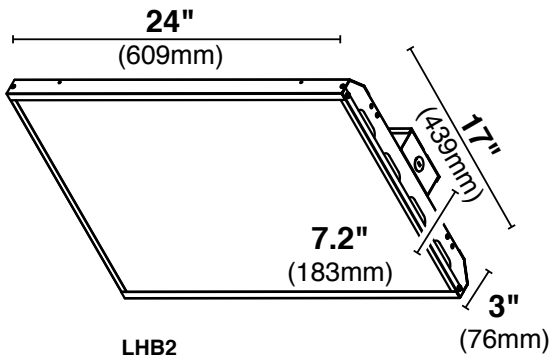

LHB2

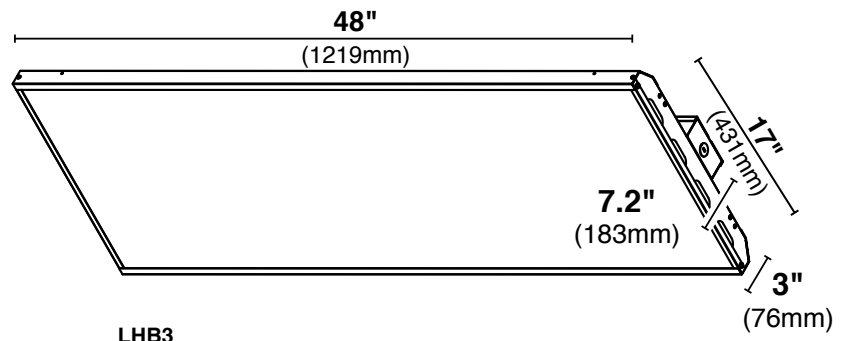

LHB3



Pendent Mount (optional)



Emergency Battery (optional)

Ordering Information



Watt [§]	Product #	Product Code	Volts [†]	Color Temp.	CRI	Lumens	Useful Life*	Pkg. Qty.	Height, Width, Length	Dimmable	DLC [®] Product ID
111	99649	LHB1/111/850/UNV/LED2	120-277V	5000K	80	15,140	110,00	1/1	3" x 13" x 24"	Yes (0-10V)	PL3BF1G73REC
161	99650	LHB2/161/850/UNV/LED2	120-277V	5000K	80	21,944	110,00	1/1	3" x 17" x 24"	Yes (0-10V)	PLSGT4CIBQG5
221	99651	LHB3/221/850/UNV/LED2	120-277V	5000K	80	30,122	110,00	1/1	3" x 17" x 48"	Yes (0-10V)	PLVP3TJYQJSV
	99652	LHB/PMA Pendent Mounting Assembly						1/24			
	81981	VPL/EM/LED3 16W Emergency Battery	120-277V					1/1			

Ordering information.

NEW ITEM

* Useful Life is defined as the point in time at which the lamp will maintain at least 70% of its initial lumens. The lamp will continue to burn past this point, but at decreased light levels.

Warranty Commercial/Industrial: This product is warranted for 5 years from the date purchase.

May not be compatible with all dimmable systems, dimming performance may vary by system, please check the website www.halcolighting.com for up-to-date dimmer compatibility information. Use on incompatible systems may shorten lamp life.

Halco Lighting Technologies 2940 Pacific Drive | Norcross, GA 30071 | Toll Free 800.677.3334 | Phone 770.242.3612 | Fax 800.880.0822 | halcolighting.com | Atlanta | Chicago | Cleveland | Houston | Los Angeles | Phoenix
 © 2018 Halco Lighting Technologies, LLC. All rights reserved. Halco and ProLED are registered trademarks of Halco Lighting Technologies. All sizes and specifications are subject to change. 03-05-18. Re-order #18989.