

LED Vaportights Commercial Series Installation Instructions



Models: LVT4CL48/850/5S/LED (99631)

IMPORTANT: READ INSTRUCTIONS CAREFULLY BEFORE INSTALLING.
KEEP THESE INSTRUCTIONS FOR FUTURE REFERENCE.

WARNING - Risk of fire or electric shock.

WARNING - Make certain power is switched OFF before starting installation or attempting any maintenance. Consult an electrician if not qualified to prevent electrical shock.

Application/ Use:

This product is rated for use in wet locations and designed for surface and suspended mounting applications.

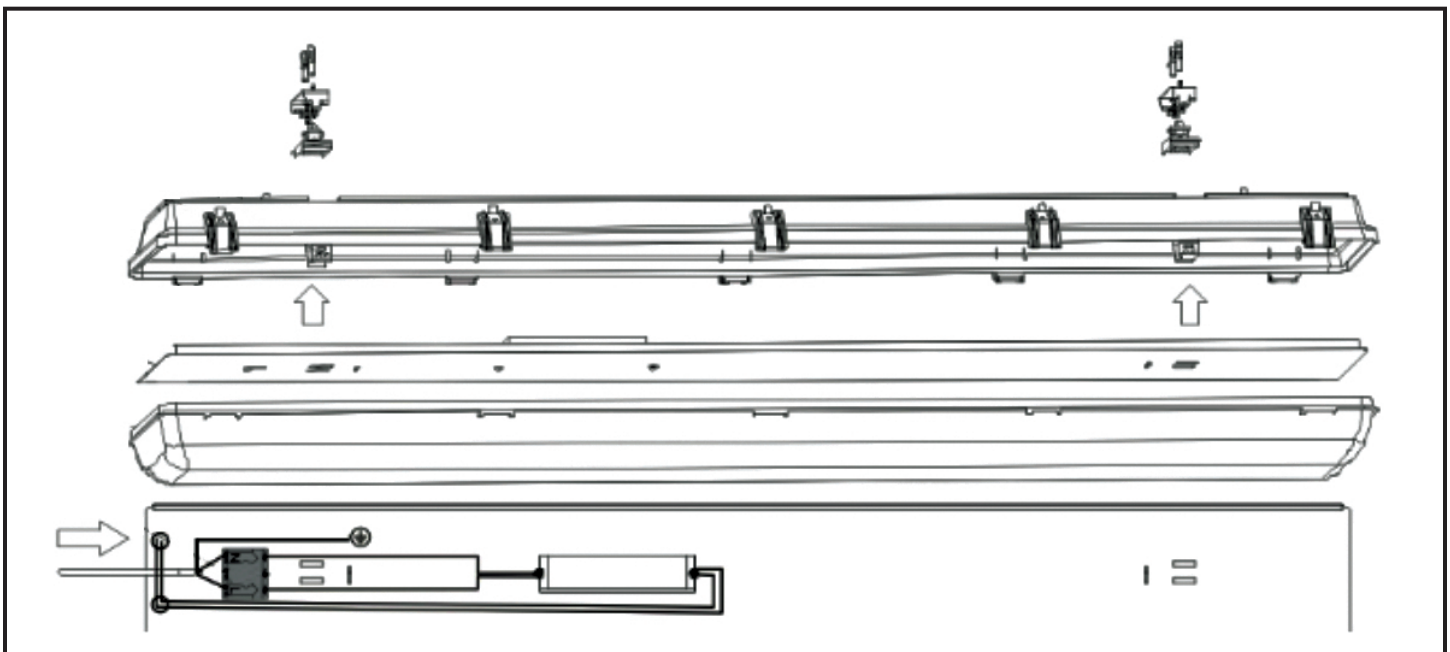
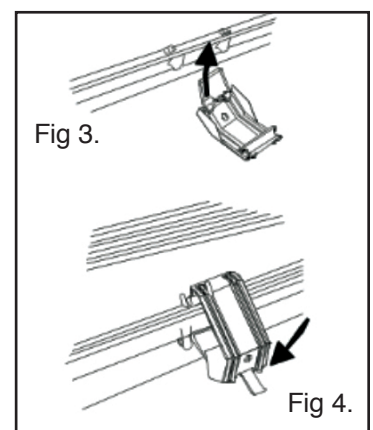
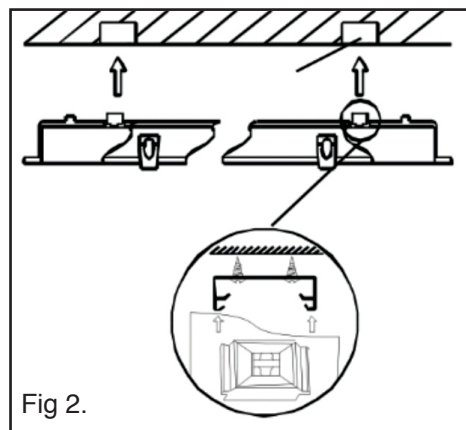
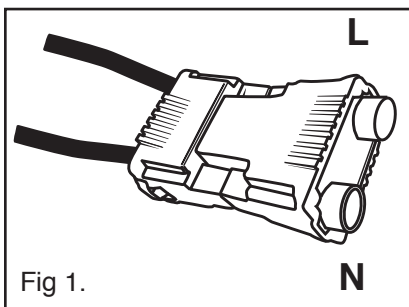

Installation steps:

STEP 1: Electrical work needs to be completed by a qualified electrician.

STEP 2: Disconnect the luminaire from the power supply and let the luminaire cool down before replacing.

STEP 3: Never open a luminaire when the power is on.

STEP 4: In case of damages, disconnect the luminaire from the power supply. Do not try to repair the luminaire on your own.

STEP 5: Drill the fitting holes at the place of installation (wall/ ceiling), make sure that no cables or other lines are passing at place of drilling.

STEP 6: Put the screws in the holes and secure the luminaire in place.

STEP 7: Insert the power cable (Type SJTW, 18AWG, min 80°C) connected to the connector, through the bushing in the opening.
(By slightly pulling, the position of the washer can be optimized)

STEP 8: When Connecting the connector, pay attention to the correct polarity **L** and **N** (See Fig.1a).

Warning: Ensure the cable is connected well, and cover the outlet box with the canopy, be sure providing watertight seal between canopy and mounting surface by using silicone building sealant or similar caulking.

STEP 9: The reflector should be permanently and reliably connected to the ground terminal through the grounding wire.

STEP 10: Adjust the connecting plate (7) and pay attention that the installation cable is not touching the LED driver.
The LED driver can become hot while in operation.

STEP 11: Assemble the luminaires (11) at the designated position (See Fig. 2/ 3)

STEP 12: Put on the cover (10) and fix it with the luminaires (11). All luminaires clips should be used.

IMPORTANT SAFETY INFORMATION:

CAUTION: This luminaire must be wired in accordance with the National Electrical Code and applicable local codes and ordinances. Proper grounding is required to insure personal safety. Carefully observe grounding procedure under installation section.

CAUTION: Installation and servicing of this equipment should be performed by qualified personnel only.

CAUTION: Do not mount near gas or electrical heaters.

CAUTION: Equipment should be mounted in locations and at heights where it will not readily be subjected to tampering by unauthorized personnel.

CAUTION: The use of accessory equipment not recommended by the manufacturer may cause an unsafe condition.
Any modification or use of non-original components will void the warranty and product liability.

CAUTION: Do not use this equipment for other than intended use.

CAUTION: Do not install in dead air, sheltered, buried or boxed in location. This luminaire should not be installed in areas that will entrap heat. It is not intended to be used in potentially dangerous or hazardous locations such as flammable or explosive atmospheres.

CAUTION: This luminaire is not for use with UL924 Emergency Lighting Equipment.

Troubleshooting:

- 1) Check that the line voltage at the luminaire is correct and the circuit breaker is on.
- 2) Ensure that luminaire is grounded properly.
- 3) Check for water or moisture in the luminaire or junction box.
- 4) If a photocell is used, be sure it is functioning properly.
- 5) Ensure the photocell is rated for LED loads with minimum load requirement.

Cleaning and Maintenance:

Caution: Do not clean or maintain while the luminaire is energized. Check that the luminaire temperature is cool enough to touch.
Periodically check and remove any accumulated dirt or debris from the lens and around luminaire.

- 1) Clean lens with non-abrasive glass cleaning solution.
- 2) Do not open the luminaire to clean the LED. Do not touch the LED.

Replacement Parts:

Contact your sales representative for replacement part availability.

Warranty Information:

This product is warranted for 5 years from the date of purchase.

If this product does not perform to the specifications supplied on this package, send an email or write to the address below for product return and replacement. This replacement is the sole remedy available. Liability for incidental or consequential damage is expressly excluded. Visit www.halcolighting.com for full warranty details and compatibility information.