



Product Specifications for E20516-18PC

Job Name:	Job Type:
Quantity:	Comments:



E20516-18PC
Larmes 9-Light LED Pendant

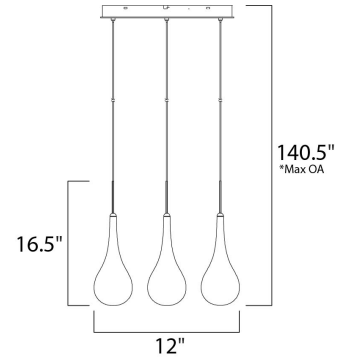

*max overall height

Finish

Polished Chrome

Glass/Shade

Clear

Product Category

Single Pendant

Lamping

Number of Bulb(s)	9
Light Type	LED
Bulb Type	G4 LED
Max Bulb Wattage	1.5
Max Fixture Wattage	13.5
Rated Life	±30,000 Hours
Rated Lumens	±945
Color Temp	±3,000 K
Bulb(s) Included	Yes
Light Up/Down	N/A
Beam Spread	N/A
CRI	N/A
Photo Cell Included	N/A
Ballast/Driver/Transformer	Yes
Dimmable	Standard/Lutron® CL or Leviton® LED

Measurements

Width	12.00"
Height	16.50"
Length	12.00"
Extension	N/A
Back Plate Width	N/A
Back Plate Height	N/A
HCO	N/A
Min Overall Height	16.50"
Max Overall Height	140.50"
Hanging Weight	14.33 lb(s)
Height Adjustable	N/A
Slope	N/A
Chain Length	N/A
Wire Length	N/A
Canopy Width	16.3"
Canopy Height	1.0"
Canopy Length	16.3"

Shipping

Carton Weight	19.99 lb(s)
Carton Width	21.50"
Carton Height	11.00"
Carton Length	28.50"
Carton Cubic Feet	N/A
Master Pack	1
Master Pack Weight	N/A
Master Pack Width	N/A
Master Pack Height	N/A
Master Pack Length	N/A
Master Cubic Feet	N/A
UPS Shippable	Yes

Certification

Safety Rating	Dry
Energy Star	No
CA Title 24	No
CA Title 20	No
ADA	No

Other

UPC Code	845094060963
Material	N/A

Equivalents

Incandescent Watts	N/A
Fluorescent Watts	N/A

ET2 Contemporary Lighting and all designs, logos and images © 2016 ET2 Contemporary Lighting. All Rights Reserved. ET2 Contemporary Lighting reserves the right, at any time, to make changes in the design and/or construction of the product including the discontinuation of product without prior notice. Color may vary from what is pictured above due to limitations inherent to photographic processes. Always consult a qualified, licensed electrician before installation of any product weighing 35 pounds or more. We recommend that a qualified, licensed electrician do the installation. Always install to a mechanically sound structure.