

BZ-150

Power Pack

Installation Instructions



SPECIFICATIONS

Voltages.....	120/277VAC. 50/60Hz
Load Requirements	
Ballast.....	20amp @120/277VAC
Incandescent.....	20amp @120VAC
Motor.....	1HP @120/240VAC
Output.....	225mA @24VDC (with relay connected)
Low Voltage Input	
Control ON	12-24VDC
Hold ON	12-24VDC
Hold OFF	12-24VDC
Manual ON (momentary switch required).....	12-24VDC
Operating Temperature	32°-104°F (0-40°C)

WattStopper®

DESCRIPTION

The BZ-150 power pack is the foundation for any low voltage lighting control system. The BZ-150 supplies low voltage power to occupancy sensors and other control devices, switching line voltage in response to signals from control devices. The BZ-150 power pack is attached to existing junction boxes or mounted into fixture wiring trays.

Low voltage wiring should use at least 22-gauge wire. High voltage connections should use at least 14-gauge. Always check local building codes. After initial wiring is complete, check wiring diagrams to verify the power pack is wired correctly. Improper wiring can cause damage to the power pack, lighting system, occupancy sensor and other control devices.

INSTALLATION



WARNING
TURN POWER OFF AT CIRCUIT BREAKER
BEFORE INSTALLING POWER PACKS.



WIRING

1. Make sure power has been turned off at the circuit breaker.
2. Connect wires as shown in the following wiring diagrams, or as shown in the BI-LEVEL CONTROL section.

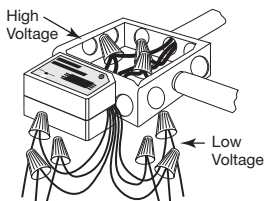

Single BZ-150 with one or more sensors

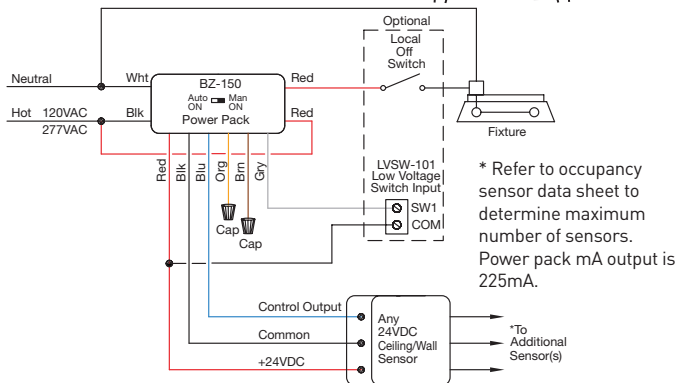

Call 800.879.8585 for Technical Support

BZ-150 with Hold On or Hold Off

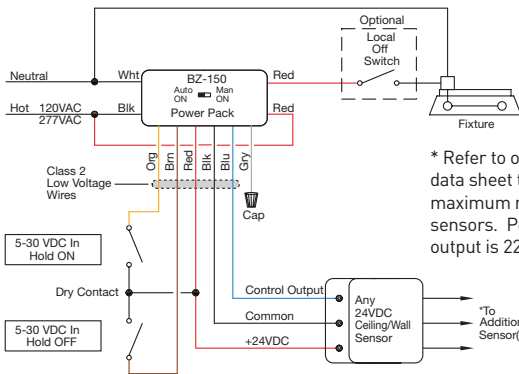

* Refer to occupancy sensor data sheet to determine maximum number of sensors. Power pack mA output is 225mA.

Installation Notes

1. Power packs should be installed in accordance with state, local and national electrical codes and requirements.
2. Power packs are designed to attach to existing or new electrical enclosures with 1/2 inch knockouts.
3. Most applications require UL listed, 18-22 AWG, 3-conductor, Class 2 cable for low voltage wiring. For plenum return ceilings, use UL listed plenum-approved cables.
4. The BZ-150 is a Class 2 Output Power Supply, suitable for parallel interconnection of up to 10 units maximum. This power pack is UL Listed for Interconnection of Power Sources in accordance with National Electric Code.

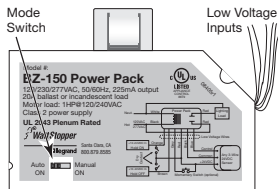

OPERATION

With the BZ-150, the load can be turned ON and OFF automatically using an occupancy sensor input, a timer, panel or BAS input, and manually from an optional low voltage momentary switch. Use the Mode Switch to select either the Auto ON mode, or the Manual ON mode. Remove power from the BZ-150 when changing the switch setting, or cycle power to it after changing the setting.

Low Voltage Momentary Switch Option Wiring

2-wire Push Button

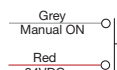

3-wire Momentary, LVS-1

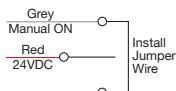

Multi-button Switch, L(x)S

Do not use pilot or locator light connections



Auto ON (Mode Switch LEFT - default)

The occupancy sensor input, Hold ON input and the optional momentary switch input can all be used turn ON the load.

When the load is turned OFF using the momentary switch, the BZ-150 does not turn it ON automatically until after the sensor time delay expires (e.g., as might be required for a presentation). Pressing the momentary switch before the sensor time delay expires turns ON the load.

When the occupancy sensor's time delay expires, the BZ-150 reverts to Auto ON mode and it turns ON the load with the next input from the occupancy sensor.

Manual ON (Mode Switch RIGHT)

Occupants must press the low voltage momentary switch to turn ON the load.

When the occupancy sensor is the only input keeping the load ON, the load turns OFF when the sensor's time delay expires. If the sensor input re-triggers within 30 seconds after the load turns OFF, the load turns ON again. After 30 seconds expire with no sensor input, press the momentary switch to turn ON the load.

LOW VOLTAGE INPUTS

Four +12-24VDC input wires are provided to control the load relay. The inputs may be used in combination or individually, depending on the needs of the application. See the WIRING section for wiring information.

Maintained Inputs:

Control ON (Blue) – This input is intended for occupancy sensor input.

Applying 12-24VDC closes the relay.

Remove the voltage and the relay opens if no other input is holding it closed.

Hold ON (Orange) – This input is intended for timer or panel input.

Applying 12-24VDC closes the relay.

Remove the voltage and the relay opens if no other input is holding it closed.

It overrides Control ON input.

Hold OFF (Brown) – This input is used for timer, panel, BAS or load shed input.

Applying 12-24VDC opens the relay.

Remove the voltage and the relay can accept any other input.

It overrides Control ON and Hold ON inputs.

Momentary Input:

Manual ON/OFF (Grey) – This input is for a low voltage momentary switch.

Applying 12-24VDC momentary input changes the relay to the opposite state.

It overrides Control ON, Hold ON and Hold OFF inputs.

BI-LEVEL CONTROL WITH MANUAL ON

The diagram to the right shows how to configure BZ-150s to provide bi-level lighting control with both Automatic ON and Manual ON features.

As shown, upon occupancy detection load A turns ON automatically.

To turn ON load B the user must press momentary switch B. Both loads turn OFF automatically when the sensor time delay expires, or manually using switch A and B.

* Refer to occupancy sensor data sheet to determine maximum number of sensors. Power pack mA output is 225mA.

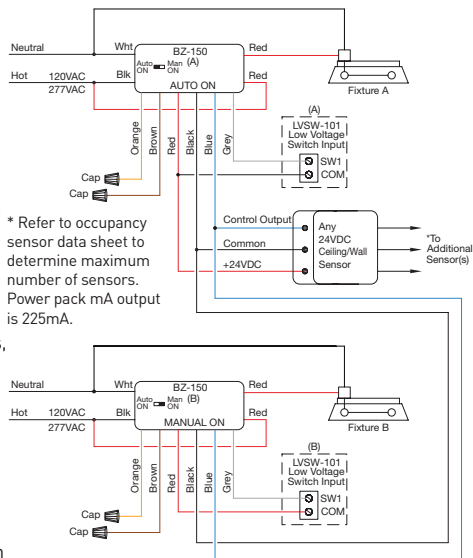

Over Current Protection

The BZ-150 contains built-in short circuit and thermal protection circuitry that shuts down the +24VDC output (low voltage red wire) to prevent permanent damage to the power pack.

Removing the excess load from the output restores the BZ-150 to proper operation. Connect the excess load to another power pack.

LED Indicator

The LED on the reverse side of the BZ-150 indicates the following conditions:

- **LED OFF:** no power to the BZ-150, or the +24VDC output is shorted.
- **LED blinking continuously:** current output limit is exceeded (too many sensors are connected to the power pack); +24VDC output shut down.
- **LED ON, blinks once every 4 or 5 seconds:** the relay is closed (load ON).
- **LED ON continuously:** the relay is open (load OFF).

TROUBLESHOOTING

The lights came ON automatically after I deliberately turned them OFF for a presentation.

- The BZ-150 is set for the Auto ON Mode and the occupancy sensor time delay expired. The BZ-150 reverted to Auto ON and then motion was detected.

- ▶ Consider increasing occupancy sensor sensitivity and/or time delay
- ▶ Generate more motion during presentations.

The load does not turn ON with occupancy detection.

- Mode Switch is set to Manual ON.
- Hold OFF input is active.

The load does not turn OFF after sensor time delay expires.

- Hold ON input is active.

The load does not respond when I press the momentary switch.

- Check wiring.

The load does not come on automatically although the Mode Switch is set to Auto ON.

- Cycle power to the unit to reset operating mode to Auto ON. Mode Switch location was changed while the power pack was was powered (line voltage).

The load comes on automatically with occupancy although the Mode Switch is set to Manual ON.

- Cycle power to the unit to reset operating mode to Manual ON. Mode Switch location was changed while the power pack was was powered (line voltage).

ORDERING INFORMATION

Load Range

Catalog No.	Description	Input Voltage	Ballast (A)	Incan. (A)	Motor (hp)	Output
BZ-50	Power Pack	120/ 277VAC, 50/60Hz	20	20	1	24VDC, 225mA w/relay connected
BZ-150	Power Pack, Hold ON/OFF, Manual ON	120/ 277VAC, 50/60Hz	20	20	1	24VDC, 225mA w/relay connected

WARRANTY INFORMATION

WattStopper warrants its products to be free of defects in materials and workmanship for a period of five (5) years. There are no obligations or liabilities on the part of WattStopper for consequential damages arising out of, or in connection with, the use or performance of this product or other indirect damages with respect to loss of property, revenue or profit, or cost of removal, installation or reinstallation.

2800 De La Cruz Boulevard,
Santa Clara, CA 95050
800.879.8585
www.wattstopper.com

Please
Recycle

WattStopper[®]

08616r5
1/2016

